

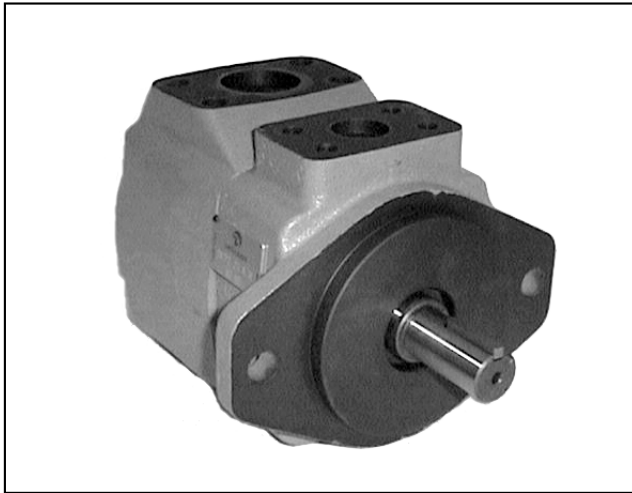

**DIPLOMATIC
HYDRAULICS**

13 100/102 ED



DFP

FIXED DISPLACEMENT VANE PUMPS SERIES 20

OPERATING PRINCIPLE

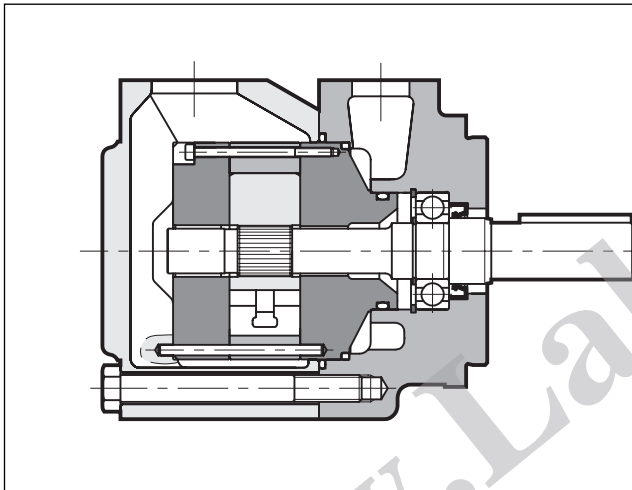

- The DFP pumps are fixed displacement vane pumps made in four different sizes, each size having five different nominal displacement. They are available with one pumping element (single pump) or with double pumping element (double pump). See par. 15 ÷ 20 for the combinations of double pumps.
- The pumping group is composed of a cartridge type compact element that contains the rotor, the vanes, the cam ring and the head disks. The cartridge is easily removable without the need to disconnect the pump from the hydraulic circuit, thus simplifying the maintenance operations.
- The special elliptical profile of the cam ring, with double suction and delivery chambers one against the other, eliminates the radial thrusts on the rotor, decisively reducing wear of the pump. In addition, the use of a 12-vane rotor reduces the delivery pressure pulsations, suppressing the vibrations and noise level of the pump.

TECHNICAL SPECIFICATIONS

DFP PUMP SIZE		1	2	3	4
Displacement range	cm ³ /rev	18 ÷ 45,9	40,1 ÷ 67,5	69 ÷ 121,6	138,6 ÷ 193,4
Flow rate range (at 1.500 rpm)	l/min.	26,1 ÷ 69,6	58,8 ÷ 99,8	101,4 ÷ 177,3	203,4 ÷ 285
Operating pressures		see table 3 - Performance ratings			
Rotation speed		see table 3 - Performance ratings			
Rotation direction		clockwise or anticlockwise (seen from the shaft side)			
Loads on the shaft		axial loads are not allowed			
Hydraulic connection		flange fittings SAE J518 (see par. 22)			
Type of fastening		flanged SAE			
Mass (single pump)	kg	12	15	23	34

Ambient temperature range	°C	-20 ÷ +50
Fluid temperature range (see par. 4)	°C	-10 ÷ +70
Fluid viscosity range	see par. 4.2	
Recommended true viscosity	cSt	25 ÷ 50
Degree of fluid contamination	see par. 4.3	

HYDRAULIC SYMBOL

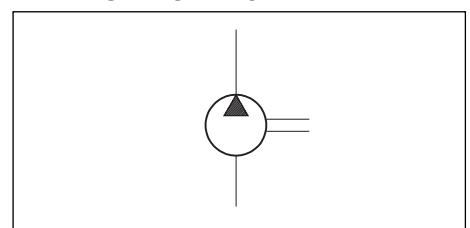



1 - IDENTIFICATION CODE

D	F			-	/							/	20	/	
----------	----------	--	--	---	---	--	--	--	--	--	--	---	-----------	---	--

Fixed displacement vane pump

Pump type
P = single pump
DP = double pump
C = shaft side cartridge or for single pump
CC = cover side cartridge

Pump size:
 - single pump
 - shaft side pump
 (only for double pumps):
1 = from 18 to 45,9 cm³/rev
2 = from 40,1 to 67,5 cm³/rev
3 = from 69 to 121,6 cm³/rev
4 = from 138,6 to 193,4 cm³/rev

Added pump size
 (only for double pumps):
1 = from 18 to 45,9 cm³/rev
2 = from 40,1 to 67,5 cm³/rev
3 = from 69 to 121,6 cm³/rev

NOTE: the cover side pump must be at least one size smaller than the shaft side pump

Size:
 - single pump
 - shaft side pump
 - shaft side cartridge
 (see performance ratings table, par. 3)

Seals: omit for mineral oils
V = viton for special fluids

Series No. (the overall and mounting dimensions remain unchanged from 20 to 29)

Type of shaft end
1 = with key
 other shaft types are available upon request

Cover side delivery port orientation compared with the shaft side delivery - for double pumps (omit for single pumps or cartridges)
A = aligned on the same side
B = at 90°
C = opposed to each other
D = at 270° } see par. 2

Suction opening orientation compared with the delivery (omit for cartridges)
A = aligned on the same side
B = at 90°
C = opposed to each other
D = at 270° } see par. 2

Rotation direction (seen from the shaft side)
R = clockwise **L** = anticlockwise

Size (only for double pumps)
 - cover side pump
 - cover side cartridge
 (see performance ratings table, par. 3)

2 - PORTS ORIENTATION

<p>SINGLE PUMPS</p> <p>DFP1</p> <p>DFP2 DFP3 DFP4</p>	<p>DOUBLE PUMPS</p> <p>DFP21 DFP31 DFP32 DFP41 DFP42</p> <p>DFP43</p>
--	--



3 - PERFORMANCE RATINGS (obtained with mineral oil with viscosity of 32 cSt at 40°C)

PUMP SIZE	NOMINAL DIMENSION	DISPLACEMENT [cm ³ /rev]	MAX. FLOW RATE (at 1500 rpm) [l/min.]	MAX. OPERATING PRESSURE (at 1500 rpm) [bar]	MAX. ROTATION SPEED [rpm] (see par. 5)	MIN. ROTATION SPEED [rpm]
DFP1	05	18	26,1	210	2700	600
	08	27,4	39,4			
	11	36,4	52,6			
	12	39,5	58,7	160		
	14	45,9	69,6	140		
DFP2	12	40,1	58,8	210	2500	600
	14	45,4	65,7			
	17	55,2	80,2			
	19	60,1	88,7			
	21	67,5	99,8			
DFP3	21	69	101,4	210	2400	600
	25	81,6	120,1			
	30	97,7	141,2			
	35	112,7	167,2			
	38	121,6	177,3			
DFP4	42	138,6	203,4	175	2200	600
	47	153,5	222,7			
	50	162,2	234			
	57	183,4	267			
	60	193,4	285			

4 - HYDRAULIC FLUID

4.1 Fluid type

TYPE OF FLUID	MAXIMUM PRESSURE (bar)				MAXIMUM SPEED (rpm)				MAXIMUM FLUID TEMPERATURE [°C]
	DFP1	DFP2	DFP3	DFP4	DFP1	DFP2	DFP3	DFP4	
HFD PHOSPHATE ESTERS	175	175	175	175	1200	1200	1200	1200	≤ 70
HFC WATER GLYCOL	140	140	140	140	1500	1500	1500	1500	≤ 50

NOTE 1: The maximum suction pressure allowed, with all fluid types, is 1,4 bar. The minimum suction pressure varies from -0,2 bar with mineral oil to -0,1 bar with the other fluid types (the pressure values are to be considered relative).

The pressures, the maximum allowed speeds and the recommended temperatures according to the different types of hydraulic fluids used are shown in the table.

4.2 - Fluid viscosity

The operating fluid viscosity must be within the following range:

minimum viscosity	16 cSt	referred to the maximum temperature of 80 °C of the fluid
optimum viscosity	25 ÷ 50 cSt	referred to the operating temperature of the fluid in the tank
maximum viscosity	800 cSt	limited to only the pump start-up phase

When choosing the fluid type, verify that the true viscosity at the operating temperature is within the above range.

4.3 - Degree of fluid contamination

The maximum degree of fluid contamination must be according to NAS 1638 class 9; therefore, use of a filter with $\beta_{20} \geq 75$ is recommended. A degree of maximum fluid contamination according to NAS 1638 class 7 is recommended for optimum endurance of the pump. Hence, use of a filter with $\beta_{10} \geq 100$ is recommended. In the event that a filter is installed on the suction line, be sure that the pressure at the pump inlet is not lower than the values specified in note 1 of par. 3.

The suction filter must be equipped with a by-pass valve and, if possible, with a clogging indicator.



5 - MAXIMUM SPEED CORRECTION FACTOR

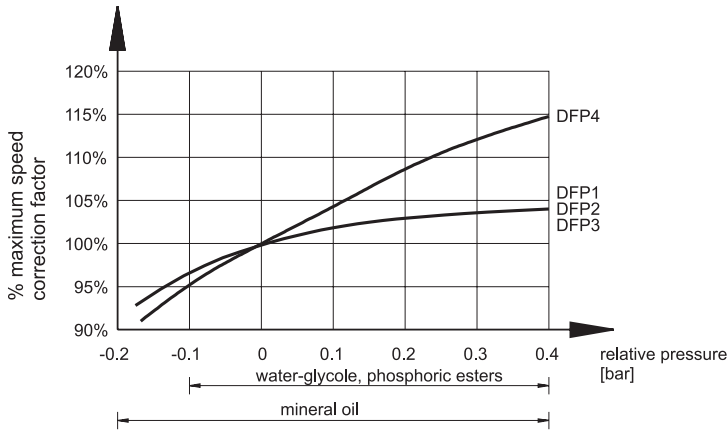

In the case that the pressure in the suction line is different than zero, the maximum rotation speed shown in table 3 must be multiplied by the correction factor obtained from the diagram seen on the left.

6 - PRESSURE PEAK (values obtained with mineral oil with viscosity of 32 cSt at 40°C, delivery pressure 140 bar and suction pressure 0 bar)

The maximum allowed over pressure on the pump delivery according to the pressure peak residency time is shown in the diagrams. The curves are valid for both single pumps and double pumps.

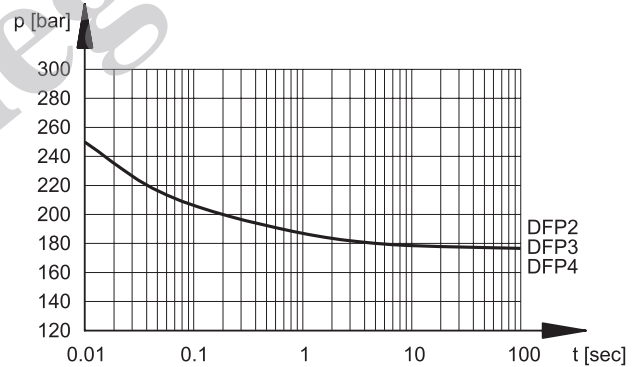
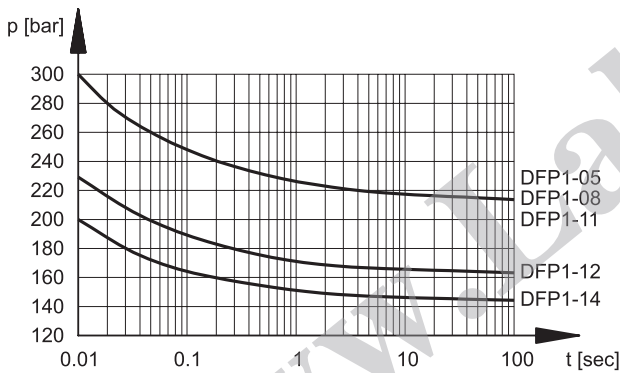

7- NOISE LEVEL (values obtained with mineral oil with viscosity of 32 cSt at 40°C, delivery pressure 140 bar and suction pressure 0 bar)

The diagram curves were measured in a semi-anechoic room according to ISO 4412/1 at a distance of 1 m from the pump. The values refer to the intermediate size pump.

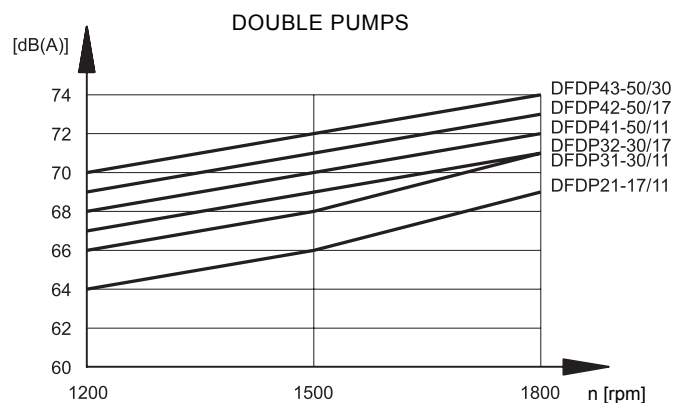
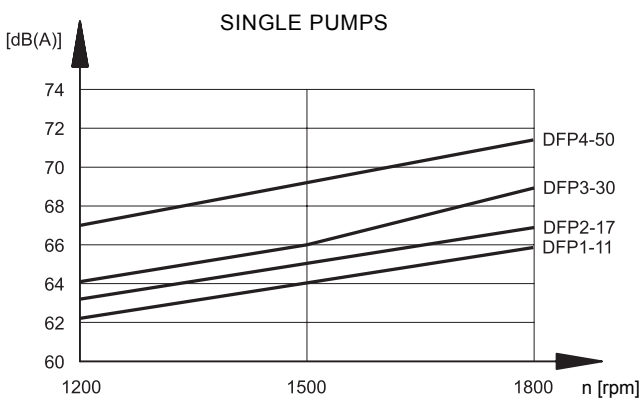



8 - DFP1 PUMP CHARACTERISTIC CURVES (obtained with mineral oil with viscosity of 32 cSt at 40°C)

FLOW RATE/PRESSURE CURVES (measured at 1500 rpm)

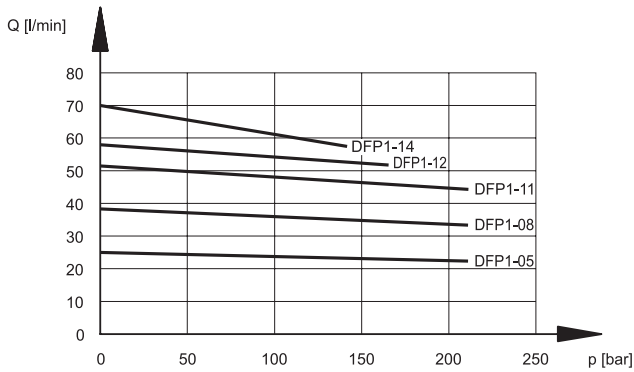

ABSORBED POWER/PRESSURE CURVES (measured at 1500 rpm)

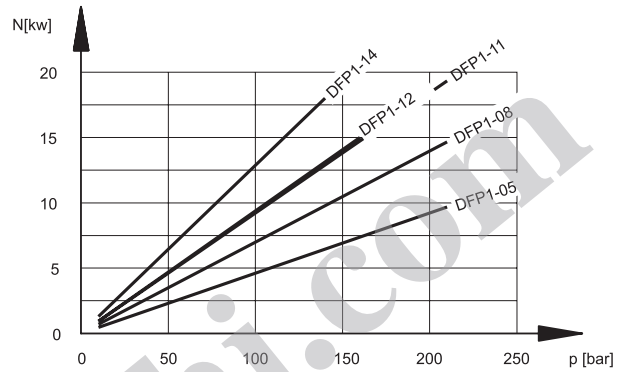

8 - DFP2 PUMP CHARACTERISTIC CURVES (obtained with mineral oil with viscosity of 32 cSt at 40°C)

FLOW RATE/PRESSURE CURVES (measured at 1500 rpm)

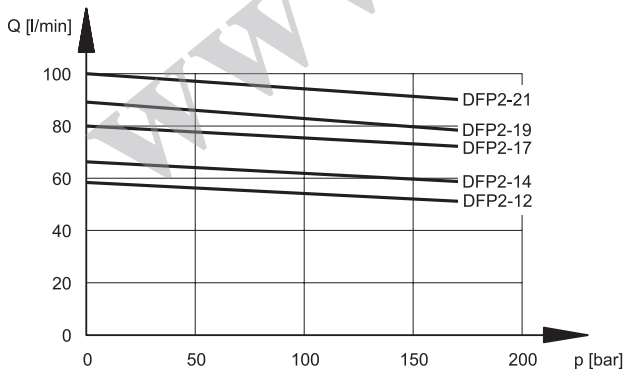

ABSORBED POWER/PRESSURE CURVES (measured at 1500 rpm)

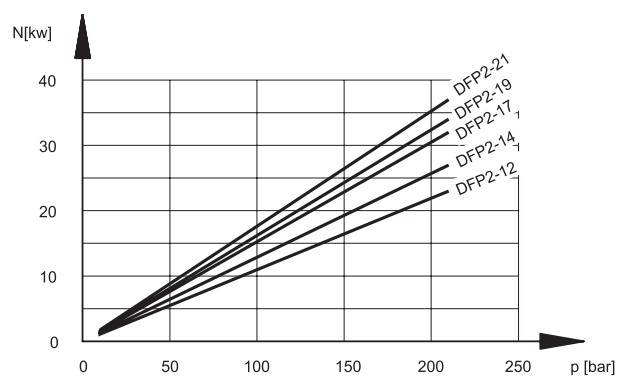



9 - DFP3 PUMP CHARACTERISTIC CURVES (values obtained with mineral oil with viscosity of 32 cSt at 40°C)

FLOW RATE/PRESSURE CURVES
(measured at 1500 rpm)

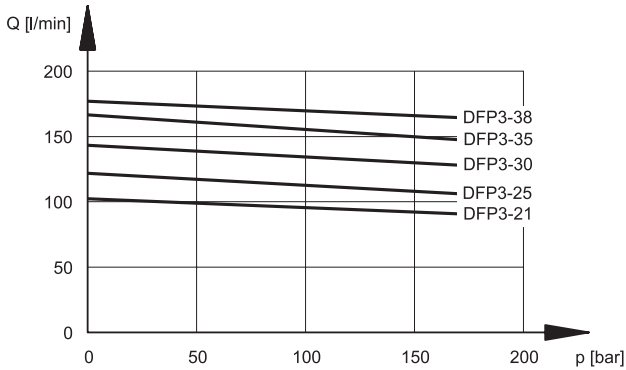

ABSORBED POWER/PRESSURE CURVES
(measured at 1500 rpm)

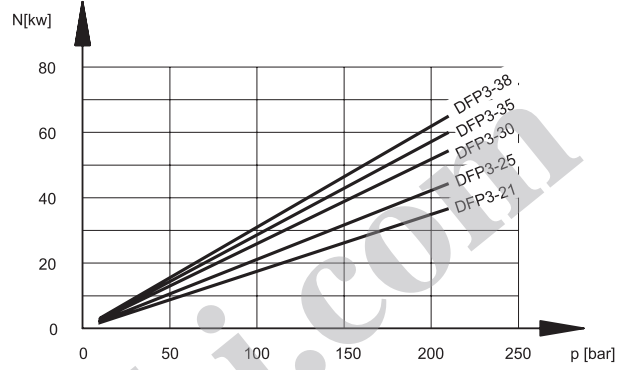

10 - DFP4 PUMP CHARACTERISTIC CURVES (values obtained with mineral oil with viscosity of 32 cSt at 40°C)

FLOW RATE/PRESSURE CURVES
(measured at 1500 rpm)

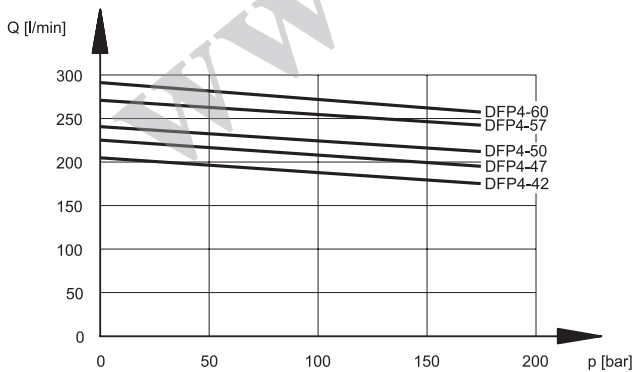

ABSORBED POWER/PRESSURE CURVES
(measured at 1500 rpm)

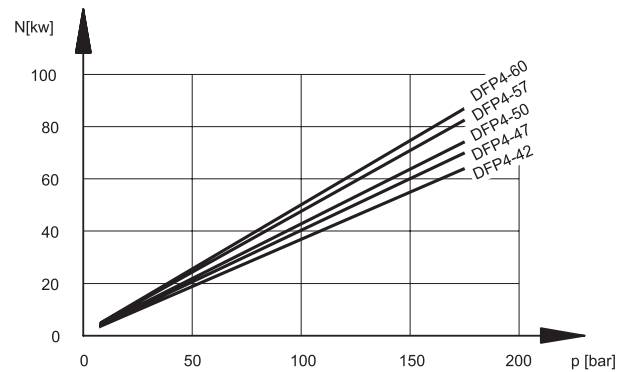



11 - DFP1 PUMP OVERALL AND MOUNTING DIMENSIONS

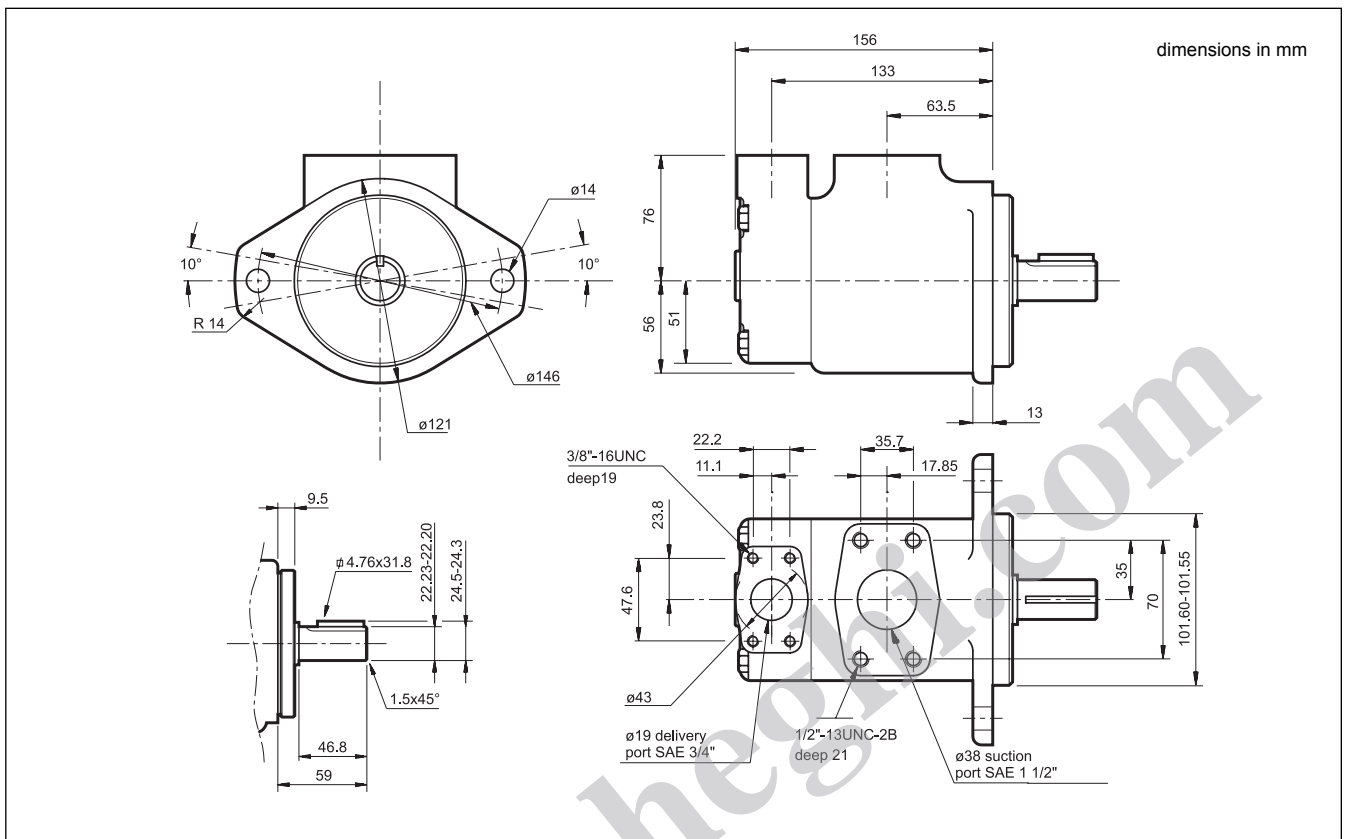

12 - DFP2 PUMP OVERALL AND MOUNTING DIMENSIONS

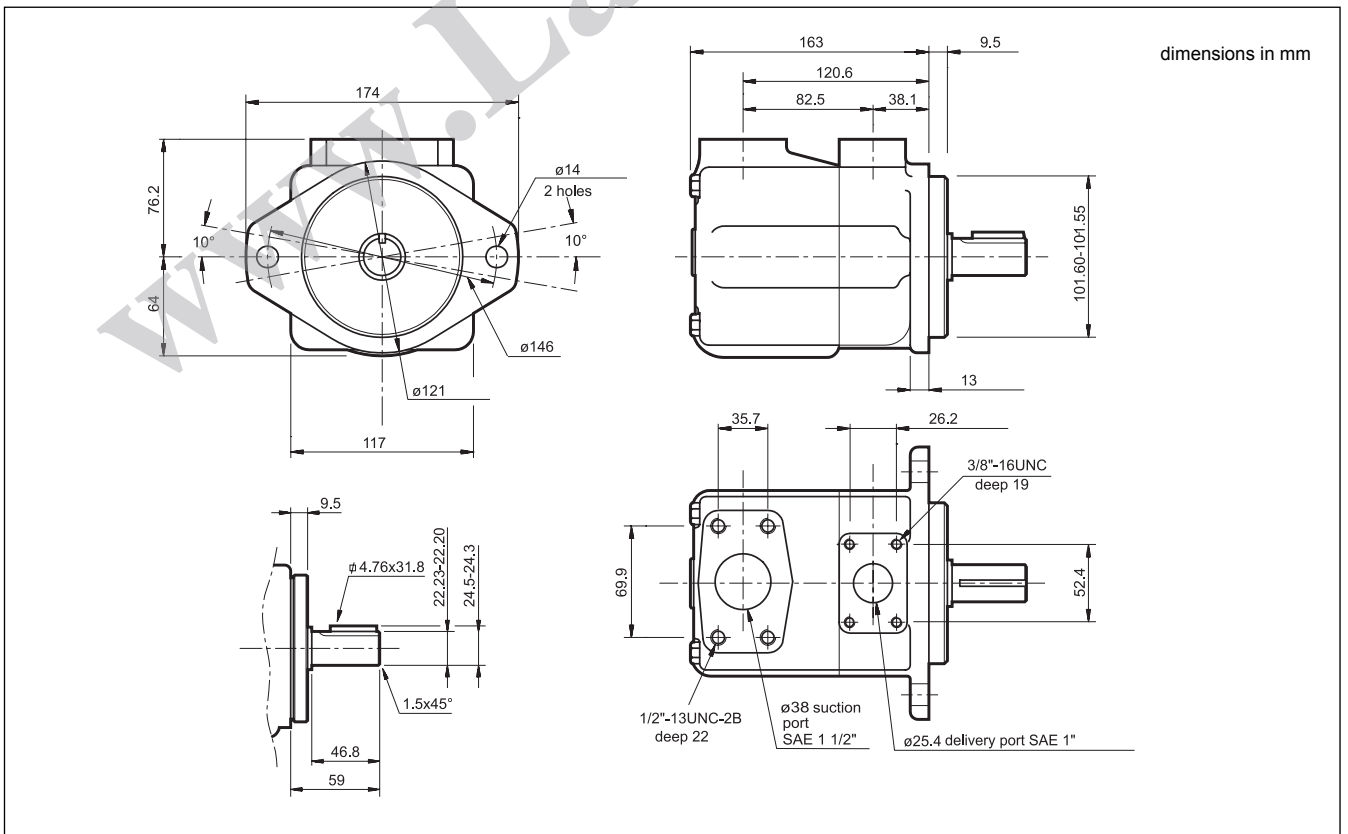



13 - DFP3 PUMP OVERALL AND MOUNTING DIMENSIONS

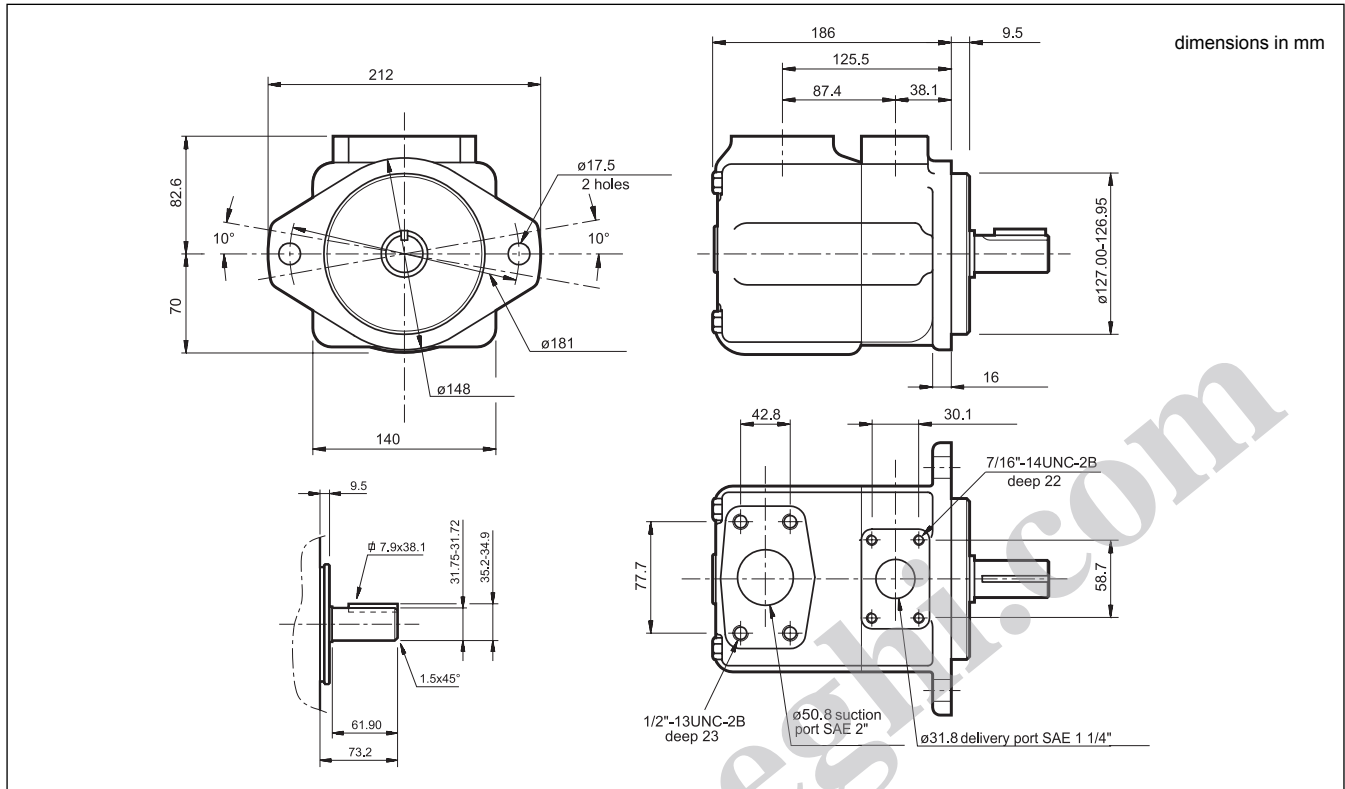

14 - DFP4 PUMP OVERALL AND MOUNTING DIMENSIONS

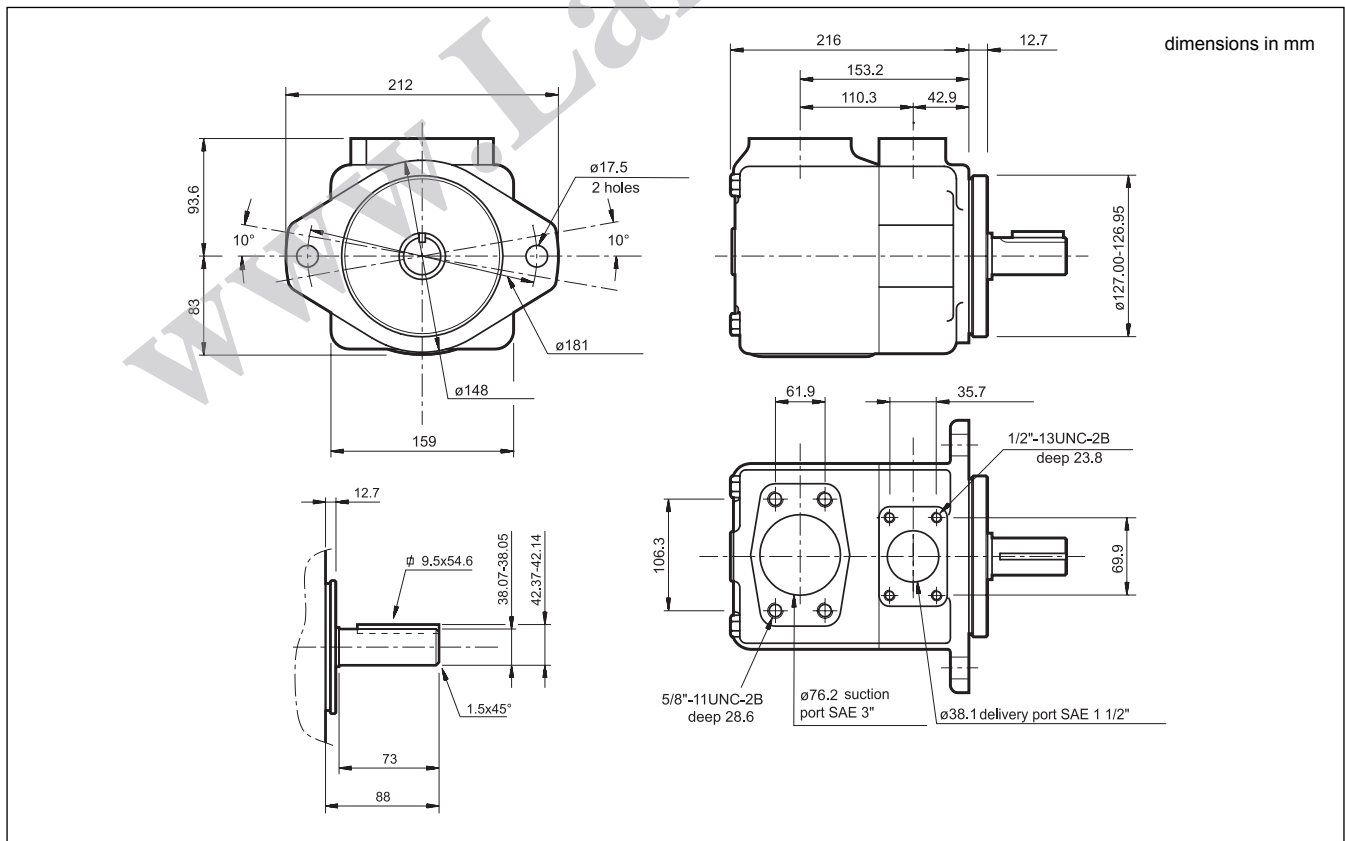



15- DFDP21 DOUBLE PUMP OVERALL AND MOUNTING DIMENSIONS

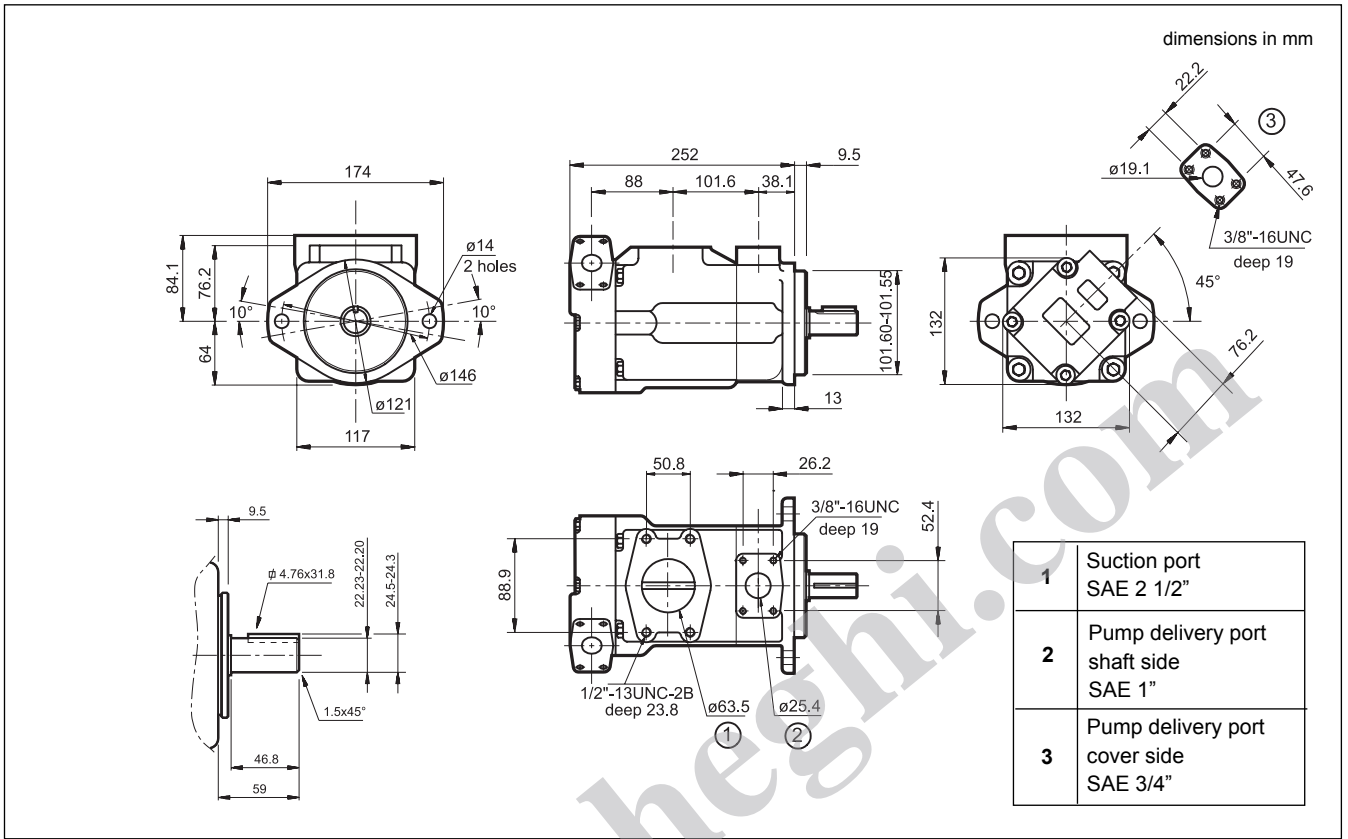

16- DFDP31 DOUBLE PUMP OVERALL AND MOUNTING DIMENSIONS

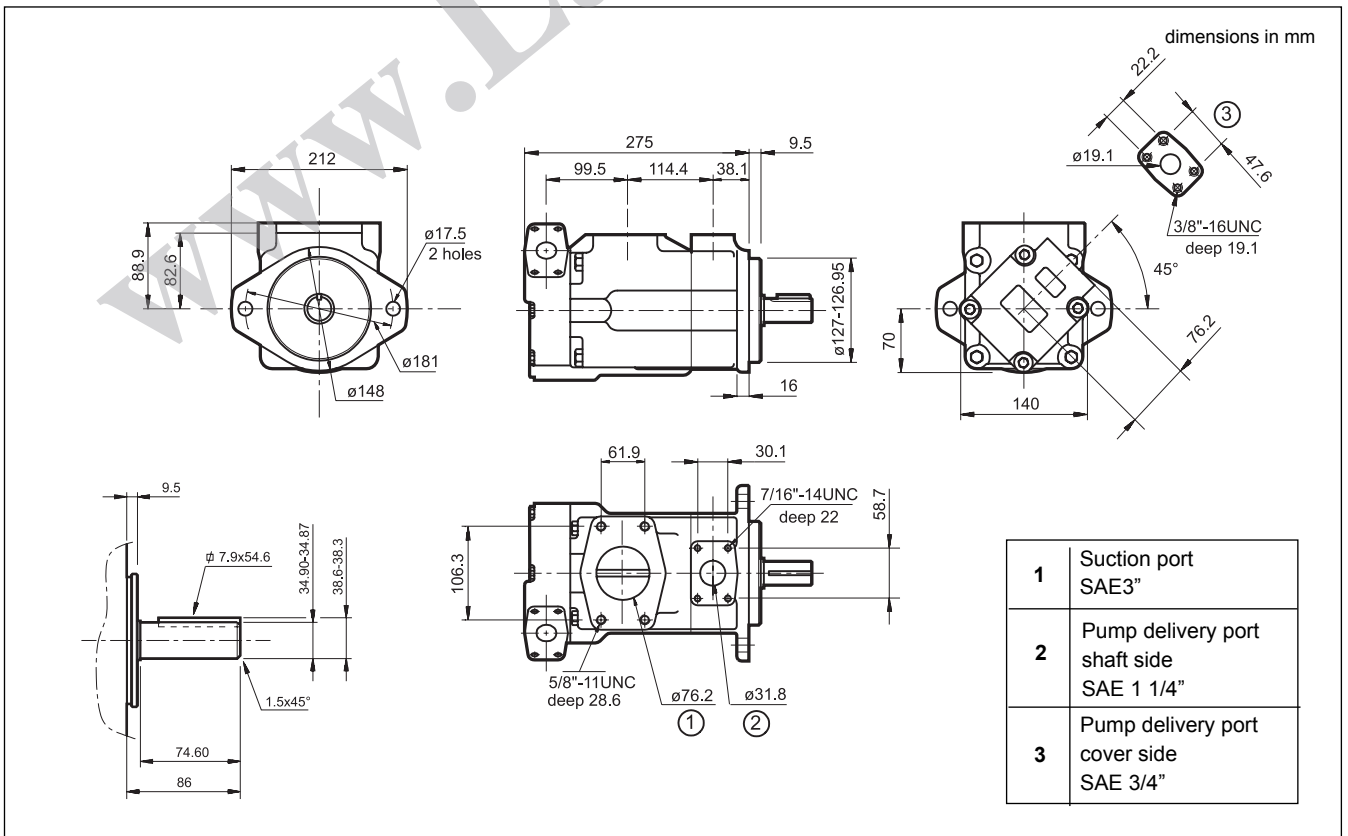



17 - DFDP32 DOUBLE PUMP OVERALL AND MOUNTING DIMENSIONS

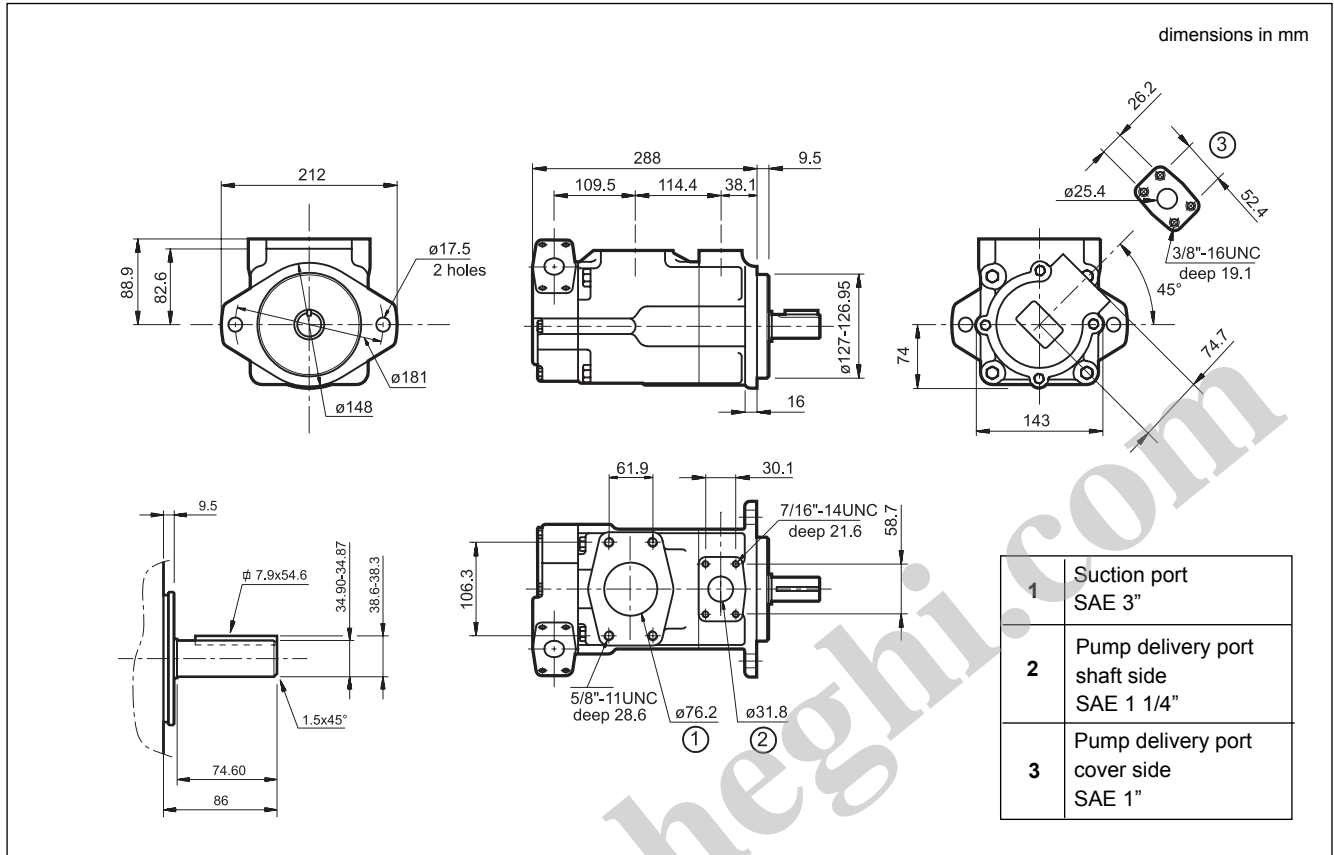

18 - DFDP41 DOUBLE PUMP OVERALL AND MOUNTING DIMENSIONS

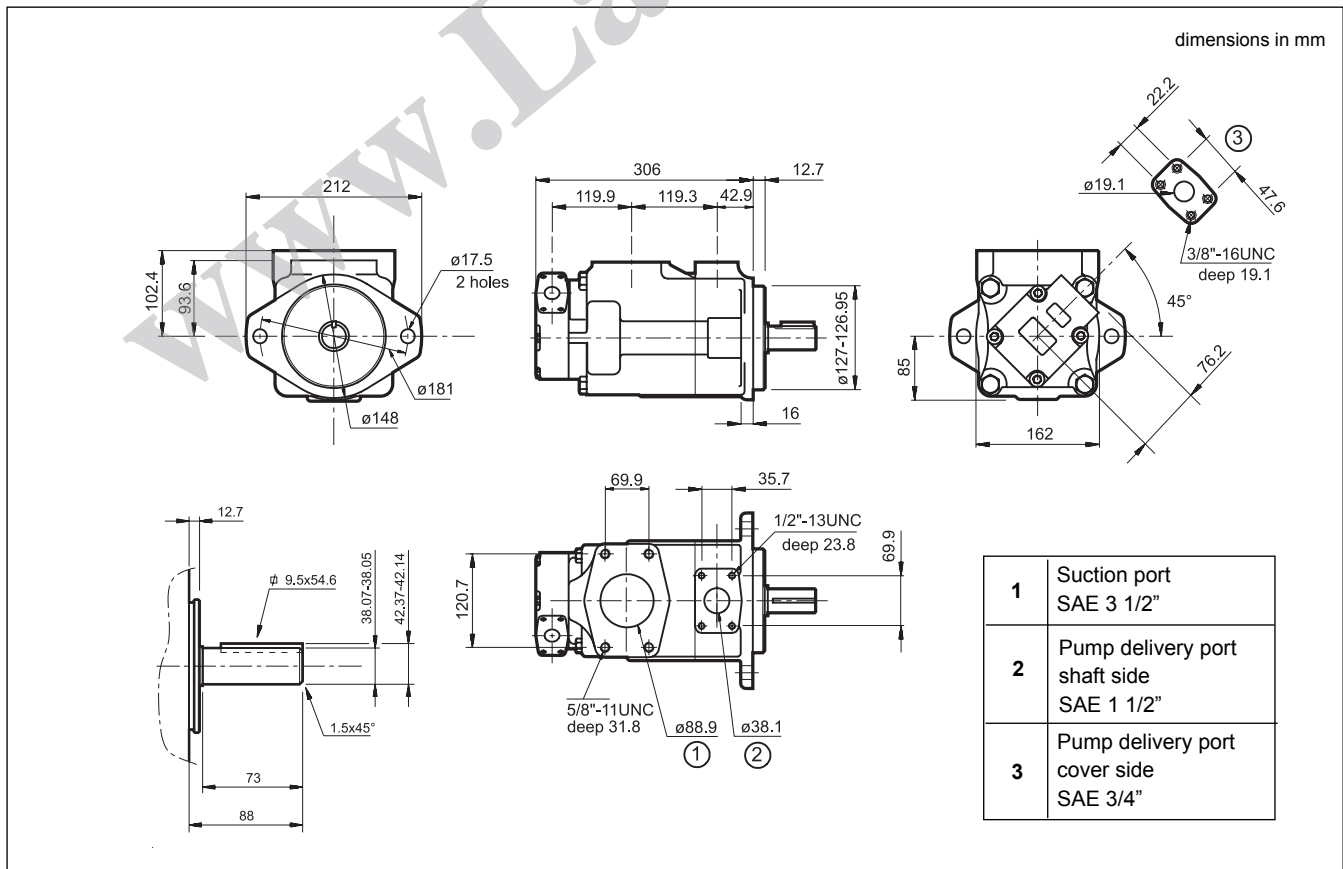



19 - DFDP42 DOUBLE PUMP OVERALL AND MOUNTING DIMENSIONS

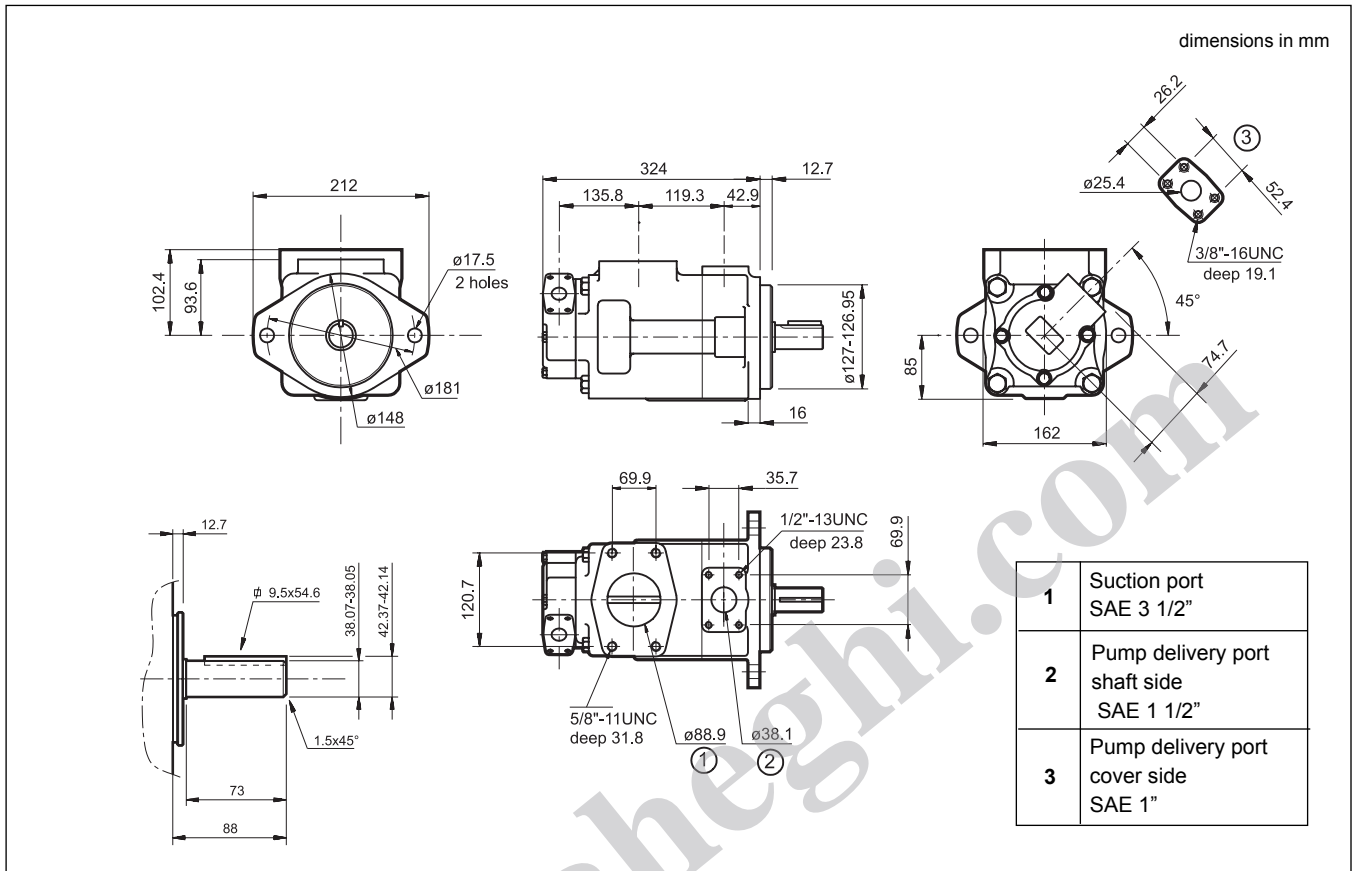

20 - DFDP43 DOUBLE PUMP OVERALL AND MOUNTING DIMENSIONS

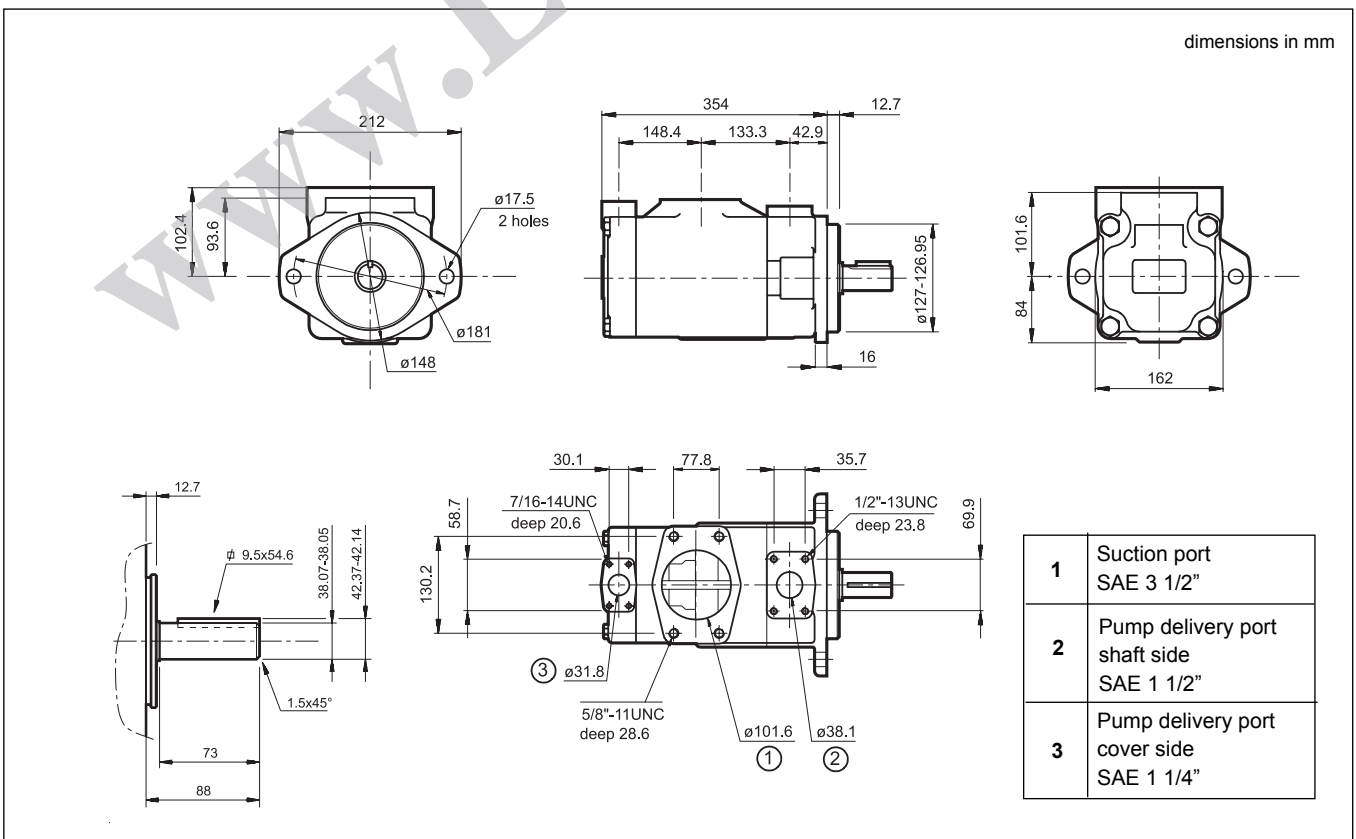



21 - INSTALLATION

- The DFP pumps can be installed with the shaft oriented in any position.
- Check that the rotation direction of the motor is according to the rotation direction of the pump before start up.
- The pump start up, especially at a cold temperature, should occur with the pump unloading.
- The suction line must be suitably sized to facilitate the flow of oil.
Bends and restrictions or an excessive line length can impair correct functioning of the pump.
- The pumps are normally positioned directly above the oil tank.
Flooded suction port installation of the pumps is advisable in the case of circuits with high flow rates and pressures.
- The motor-pump coupling must be made directly with a flexible coupling.
Couplings that generate axial or radial loads on the pump shaft are not allowed.
- Refer to paragraph 4.3 for the characteristics and installation of the filtering elements.

22 - SAE J518 CONNECTION FLANGES

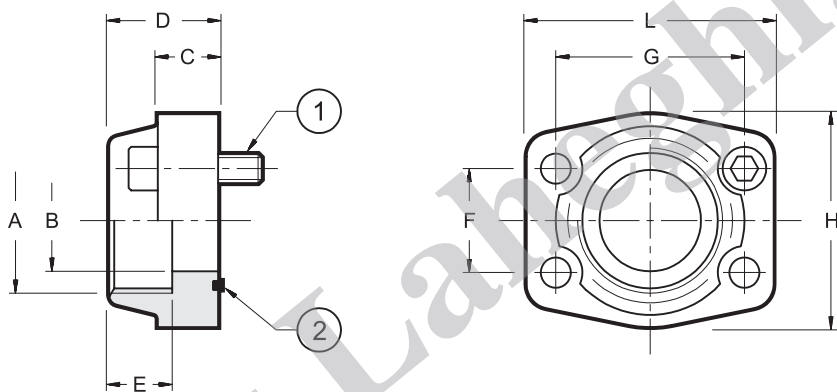

Flange code	Flange description	P _{max} [bar]	ØA	ØB	C	D	E	F	G	H	L	1 4 bolts	Bolt code	2
0610719	SAE - 3/4"	345	3/4" BSP	19	18	36	19	22,2	47,6	50	65	3/8" UNC x 1 1/2"	0530612	OR 4100
0610713	SAE - 1"	345	1" BSP	25	18	38	22	26,2	52,4	55	70			OR 4131
0610720	SAE - 1 1/4"	276	1 1/4" BSP	32	21	41	22	30,2	58,7	68	79	7/16" UNC x 1 1/2"	0530613	OR 4150
0610714	SAE - 1 1/2"	207	1 1/2" BSP	38	25	45	24	35,7	70	78	93	1/2" UNC x 1 3/4"	0530638	OR 4187
0610721	SAE - 2"	207	2" BSP	51	25	45	30	43	77,8	90	102			OR 4225
0610722	SAE - 2 1/2"	172	2 1/2" BSP	63	25	50	30	50,8	89	105	116			OR 4275
0610723	SAE - 3"	138	3" BSP	73	27	50	34	62	106,4	116	134	5/8" UNC x 2"	0530658	OR 4337
0610724	SAE - 3 1/2"	34	3 1/2" BSP	89	27	48	34	69,8	120,7	136	152			OR 4387

The fastening bolts and the O-Rings must be ordered separately.



DIPLOMATIC OLEODINAMICA SpA
20025 LEGNANO (MI) - P.le Bozzi, 1 / Via Edison
Tel. 0331/472111-472236 - Fax 0331/548328